

# ALUFIX CONCERTINAL ALLOY LOFT LADDER

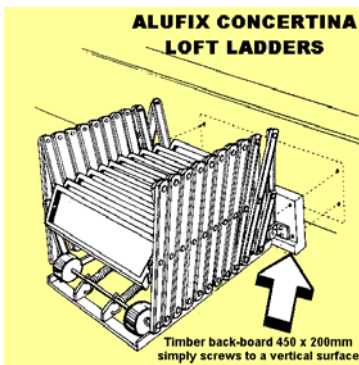

- ▶ IDEAL WHERE LOFT SPACE IS LIMITED - requires no clearance arc in loft behind trapdoor.
- ▶ Supported on a spring counterbalanced frame when stowed away.
- ▶ Easy to operate - rotate spring counterbalanced frame, lift ladder off frame and support as it extends to floor.
- ▶ Much more robust and rigid than it looks!
- ▶ Supplied fully assembled and very simple to install. Just screw timber back-board to joist above trapdoor hinges. Timber back-board dimensions 450 x 200mm W x H.
- ▶ Can also be fitted to a vertical wall, with or without a trapdoor. A 30mm thick stand-off block should be fixed behind the back-board to enable rotation into stored position when mounted on a wall.
- ▶ Large alloy treads are 3" ( 80mm ) deep with heavily ribbed non-slip surface.
- ▶ Supplied with trapdoor hinges, trapdoor catch and operating pole hook.
- ▶ Packed size - 21" x 18" x 15"
- ▶ NOTE: heights are measured to CEILING ( not Floor-to-Floor ).



## "ALUFIX CONCERTINA" ALLOY LOFT LADDERS

Code	Min & Max CEILING Heights	Loft Clearance Arc	Minimum Trapdoor Size W x L	No. Treads	Weight
TALU10	7' 9" - 8' 5" 2.35 - 2.58m	nil	20" x 24" 500 x 600mm	10	16kg
TALU11	8' 6" - 9' 3" 2.59 - 2.82m	nil	20" x 24" 500 x 600mm	11	17kg

Need a shorter Alufix Concertina loft ladder? The 10 tread model TALU10 can be easily converted into a 9 tread to fit ceiling heights 6' 11" - 7' 8" / 2.10 - 2.34m. Simply undo 8 nuts, remove one tread and re-bolt. Tread can be removed by customers or by Lansford on request

A current, detailed  
**price list**  
can be printed from our web site  
[www.ladders999.co.uk](http://www.ladders999.co.uk)

Please order at our national sales office in Bristol

All prices, details and specifications are subject to change without notice and are those ruling at date of order. E&OE.



HEAD OFFICE (HIRE & SALE)  
UNIT 10 CHANCEL CLOSE  
EASTERN AVENUE  
**GLOUCESTER** GL4 3SN  
FAX : 01452 308369

NATIONAL SALES OFFICE -  
8A EAST PARK TRAD ESTATE  
GORDON ROAD FISHPONDS  
**BRISTOL** BS5 7DR  
FAX : 0117 951 5682

**TEL: 01452 520144 TEL: 0117 935 4664**

[www.ladders999.co.uk](http://www.ladders999.co.uk) [sales@lansfordaccess.co.uk](mailto:sales@lansfordaccess.co.uk)