

MOBILE TANKER LADDER

The Tanker Ladder is a mobile counter-balanced two-part extending platform ladder with a guardrail.

The platform and guardrail allow safe, protected access to vehicle roofs, containers or tankers.



MOBILE **TANKER ACCESS** LADDER



- ▶ **Not JUST for tankers!!**
- ▶ Work safely on vehicle roofs.
- ▶ Standard design as shown or made-to-measure.
- ▶ Counterbalance weights allow wheels flush with sides.
- ▶ Height variations to suit.
- ▶ Ladder elevation by hand winch.
- ▶ Top safety cage dimensions standard or to suit.
- ▶ Supplied flat-packed in knock-down form for on-site assembly.
- ▶ Quotations on request.

- ▶ For maintenance, repairs, re-fuelling or cleaning tankers and tank wagons. But not **just** tankers!
- ▶ Tanker ladders are used for tanker lorries in the food industry, in the chemical and petrochemical industries as well as on rail-mounted vehicles.
- ▶ The tanker ladder consists of a 2-section push-up ladder (max. load 150 kg) which is readily height-adjustable by means of a hand winch mounted on the side, the side support section and a double-sided handrail. Complementing this are railings, platform and chassis of standard dimensions or to your specific requirements.
- ▶ Should the existing modular system not fulfil your requirements, we can also design and manufacture special solutions on request.

MOBILE **TANKER ACCESS** LADDER



Base Ladder Module:

Extending 2-section ladder with height adjustment by means of rope and hand winch on ladder side, with support section and handrail both sides.

Vertical platform heights adjustable **between 2.77m - 4.10m** at 274mm rung space intervals.

All Tanker Ladders are supplied knock-down in these modules for final assembly on site.

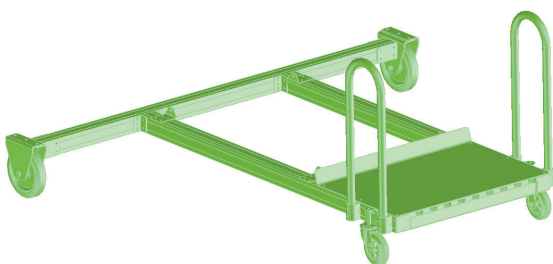

Chassis module:

two variations available with push-pull handles

Standard chassis with rigid stabiliser -

Mobile on 2 swivel and 2 braked fixed castors. Counterbalance weights fitted under alloy tread plate.

Dimensions appx 2.35m wide x 2.00m

Narrow chassis with extendable stabiliser -

extending stabiliser arms fitted with screw jacks (200mm adjustment) for optimum stability and compensation for uneven ground. Mobile on 2 swivel and 2 braked fixed castors. Counterbalance weights fitted under alloy tread plate.

Dimensions **retracted** 1.05m wide x 2.00m.

Dimensions **extended** 2.35m wide x 2.00m

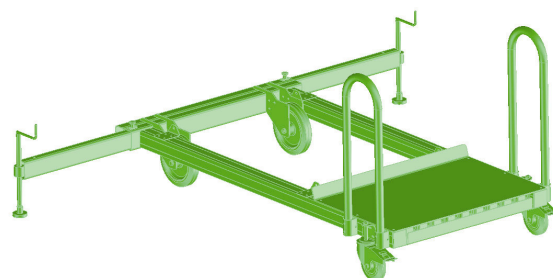

MOBILE **TANKER ACCESS** LADDER

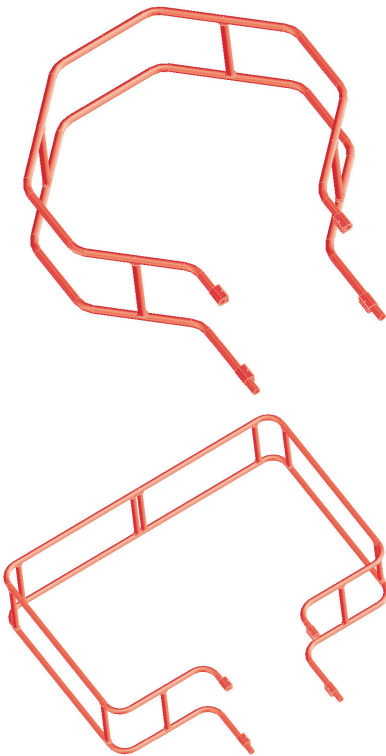

Guardrail module: choose one from the two variations available:

"Round" Guardrail apx 1500mm dia.

Rectangular Guardrail apx 2050 x 1500mm.

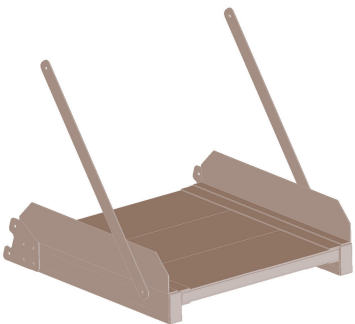

Optional modules: choose any or none:

Optional Aluminium Serrated Access Platform -

3 different Access Platforms are available in lengths of 300mm or 600mm or 800mm

to increase the safety of stepping from ladder to vehicle, especially on those with sloping sides.



Optional Additional Platform Guardrail -

with double lifting barrier may be used on the platforms 600 mm or 800 mm in length (not on 300 mm model).



Optional AntiStatic version

01452 520144 **Lansford**

MOBILE TANKER ACCESS LADDER

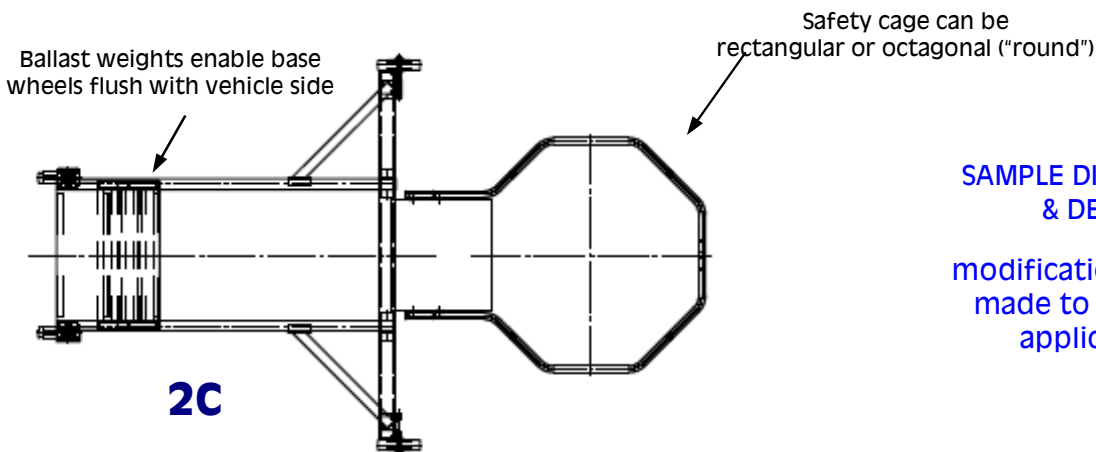
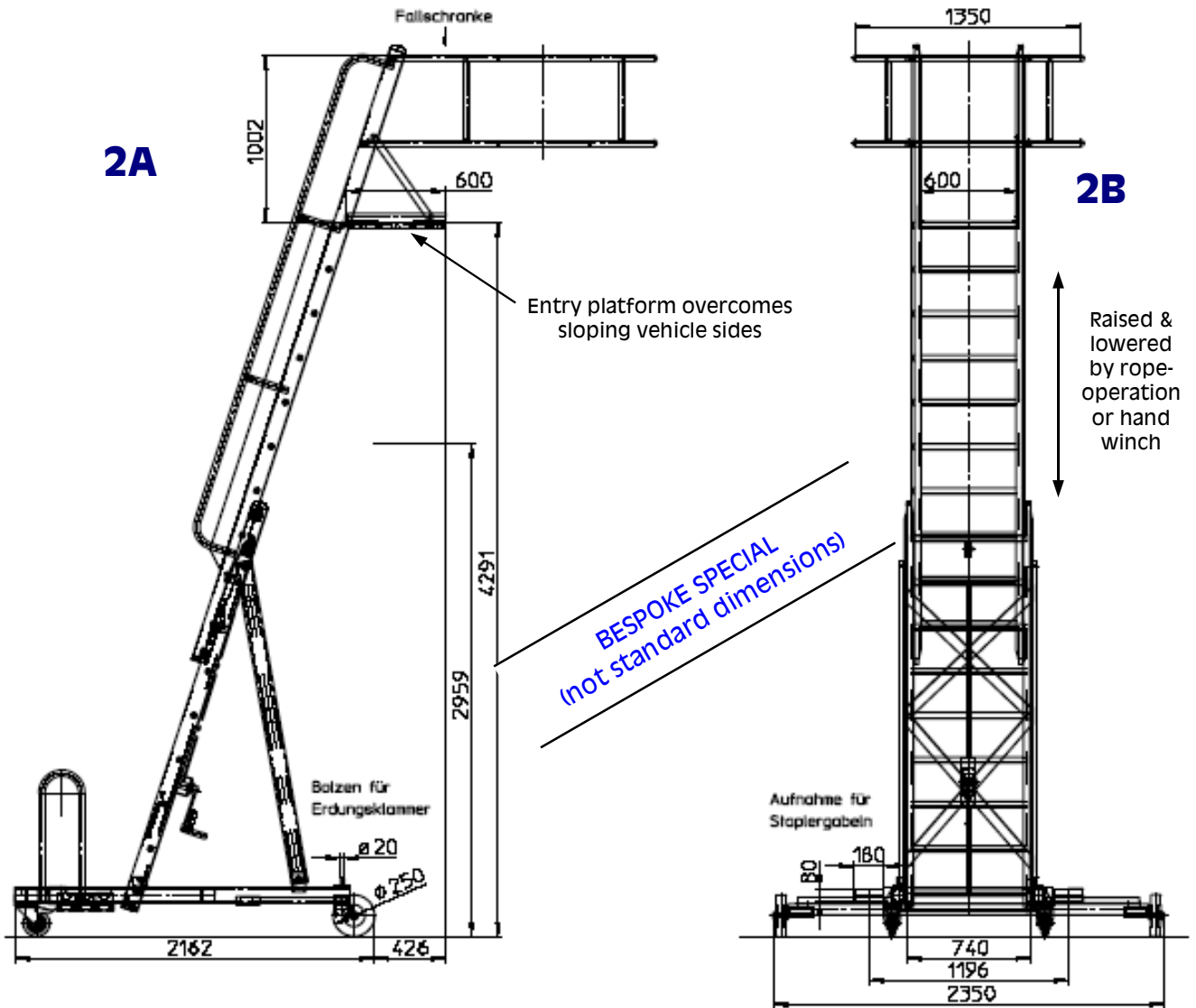

SAMPLE DIMENSIONS & DESIGN

modifications can be made to suit your application

MOBILE TANKER ACCESS LADDER

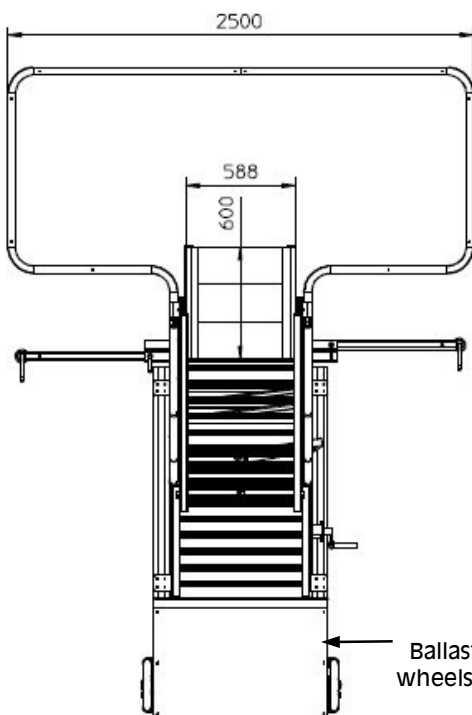
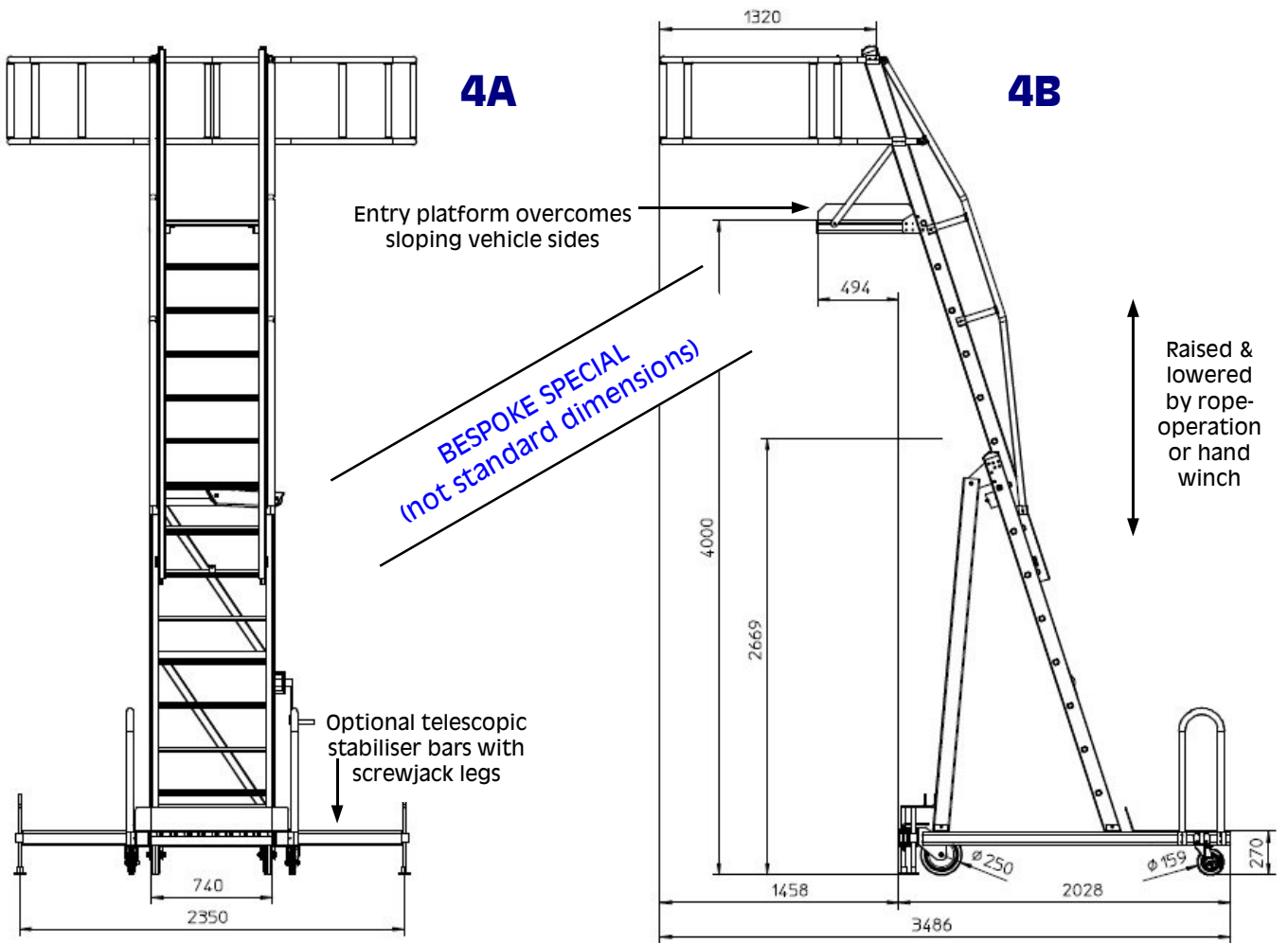

SAMPLE DIMENSIONS & DESIGN

modifications can be made to suit your application

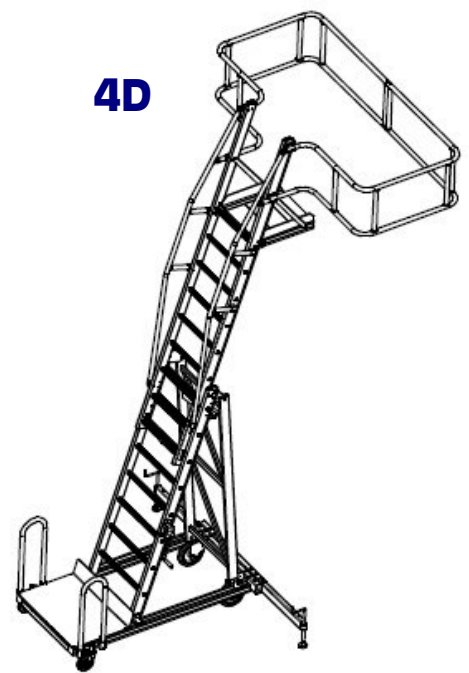

MORE SAFE **VEHICLE ACCESS** EQUIPMENT



" Loadstep " Lorry Bed Ladders
Low cost, quickly located, safe. Simply brilliant !



Mobile Steel Tanker Access Stairs
bespoke manufacture at any height to suit



Truck-Dock - standard model and 4.0m long bespoke model
mobile platforms for safe manual loading and unloading of vehicles

For full details of our
entire range, visit us at our web site
www.ladders999.co.uk



UNITS 2 & 10 CHANCEL CLOSE TRADING ESTATE
EASTERN AVENUE **GLOUCESTER** GL4 3SN
FAX : 01452 308369
TEL: 01452 520144

www.ladders999.co.uk sales@lansfordaccess.co.uk